

**BUILT
TO WORK**

TRI-BUILT® EXTERIOR TRIM INSTALLATION GUIDELINES



TRIBUILT™

INSTALLATION GUIDELINES



TRI-BUILT Exterior Trim is an exterior decorative trim for use only in non-load-bearing applications. It must never be used as a siding/cladding material. These Installation Guidelines are a general resource in standard installation techniques and procedures for working with TRI-BUILT Exterior Trim. They are meant to be as thorough as possible.

Table of Contents

Safety	1
Storage and Handling	1
Pallet Handling	2
Cutting, Drilling, Routing and Finishing	2
Expansion and Contraction	2
Fastening	3, 4
Bonding, Adhesives and Joinery	5
Rakes, Fascias and Bandboards	5
Soffit and Porch Ceilings	5
Corners	7, 8
Skirtboard	9, 10
Window and Door Trim	11
InvisiPro® Hidden Fastening System	11, 12
Column Wraps	13
Beadboard	14
Concealing Joints	15
Painting, Bending and Cleaning	15, 16
Glossary	17, 18
TRI-BUILT Exterior Trim	Back Cover

TRI-BUILT Exterior Trim looks and feels like top-grade lumber. It installs like lumber and can be cut, shaped, routed, or milled with ordinary wood-working tools. All our trimboards, sheets, and specialty millwork have a natural white surface that does not need painting. Restoration Millwork meets all ICC and CCMC code requirements.

SAFETY

TRI-BUILT exterior trim is a cellular PVC product and cutting it will create PVC dust and particles.

- Cut cellular PVC trim in an open, well-ventilated area.
- Always wear safety glasses or goggles and a face mask when cutting.
- If you cut trim with a power saw, wear a dust mask.

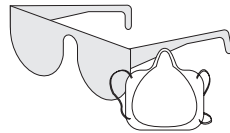

STORAGE AND HANDLING

TRI-BUILT Exterior Trim is more flexible than wood, so it may conform to uneven surfaces, particularly in warm weather.

- Store TRI-BUILT Exterior Trim up off the ground on a flat, level surface. If the product is stored in a cantilever rack, use the shipping pallet to provide support.
- TRI-BUILT Exterior Trim should not be stored or placed directly on surfaces that can develop excessive heat, such as blacktop.
- Trimboards are packaged in protective wrap for protection from scuffs and dirt. Once the protective wrap is removed, protect the trim from dirt and debris. If it does get dirty, clean the trim with a soft bristle brush and mild soap and water before you install it. The protective wrap is not meant to be a weather barrier; use the pallet shroud or a tarp when storing the product outside.
- Products with removable film should be kept dry prior to installation. Do not expose to direct sunlight for extended periods of time. Protective film can be removed prior, during or immediately after installation.
- When moving and installing TRI-BUILT Exterior Trim, handle it the same way you would handle soft pine lumber.
- Take care in the handling of column wraps to prevent tearing the tape or cracking at miter lock corner joints.

Note: When the terms "recommend" and "should" are used in this manual, the step is optional for installing TRI-BUILT Exterior Trim. However, it is included because the step represents best practice.

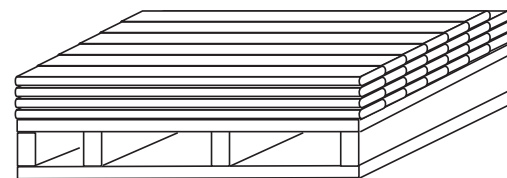

When the terms "required" and "must" are used, the step is a necessary part of the installation process and must be adhered to.

PALLET HANDLING

It is important to take certain steps when handling TRI-BUILT Exterior Trim. The below recommendations may help to keep the product in a factory-like condition prior to installation and at the job site.

- A typical TRI-BUILT Exterior Trim pallet weighs 3,200 pounds.
- TRI-BUILT Exterior Trim pallets should not be picked up two (2) at one time using standard four (4) foot wide forks.
- To pick up two (2) skids of material, a ten (10) foot fork spreader is recommended. A typical spreader can cost approximately \$3000 and can be mounted to the front of a lift truck.
- Use adjustable nylon straps around the skid and corners to protect the product where pallet bands come into contact with boards.
- Use an empty TRI-BUILT Exterior Trim skid to fill piece orders and stack product neatly. The use of edge protectors and plastic banding will help secure the skid and avoid damage.
- Avoid the use of the metal banding as these may cut into the boards if pulled too tight.
- When moving a pallet of TRI-BUILT Exterior Trim, keep the load as close to the ground as possible.

CUTTING, DRILLING, ROUTING, AND FINISHING

CUTTING

You can cut TRI-BUILT Exterior Trim with a conventional carbide-tipped blade that is designed for working with wood. Do not use fine-tooth metal-cutting blades. Do not use plywood or metal blades because the kerf of the blade is too thin and can cause heat buildup in the material. For best results, use a 32-tooth (or higher) blade designed for woodworking. To maintain a smooth edge, support the trim across its entire length when you cut it.

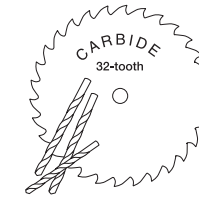

ProTip™: When it is cut properly, Restoration Millwork will have a smooth edge. If you get a rough edge from cutting, check for excessive friction, a worn saw blade, or badly aligned tools. Rasp and sand the trim to restore a smooth edge.

DRILLING

You can drill TRI-BUILT Exterior Trim with standard wood-working drill bits. Do not use bits made for rigid PVC. Avoid heat buildup from excessive friction, and remove the shavings from the drill hole frequently. To avoid binding, take precautions when using a hole saw.

ROUTING

For crisp, clean edges, use a sharp carbide-tipped bit on a router. For smooth milling, it is important to adjust the speed of the router and control the "push" rate. Hand-held routers are difficult to control, so we recommend that you mount the router (150 to 1,300 rpm) on a table.

- Make sure the router guide bearing is running along a smooth cut.
- Go over the cut a second time to smooth out the router edge.

FINISHING

TRI-BUILT Exterior Trim features our FinishedEdge™ technology, which prevents dirt from collecting on the surface of the edges. Use machine edging, sanding, grinding, or filing to finish field-cut edges. To scuff sand TRI-BUILT Exterior Trim, use 100–120 grit sandpaper or a Norton Abrasive Sponge. The finished edges will have the texture of the interior cell structure, which is a cosmetically smooth surface.

- Do not allow excessive heat to build up.
- For a smoother edge, spackle, sand, or paint the finished edge.
- Static Guard spray can be used on yourself and router to keep dust down and off of your equipment.

EXPANSION AND CONTRACTION

Vinyl building products expand and contract as the temperature changes. You must allow for this movement when you fasten TRI-BUILT Exterior Trim. You can minimize the movement of PVC trim by observing proper fastening techniques along the entire length of the trim board or sheet; using screws rather than trim nails will also help (see ProTip™ below).

- Allow 1/4 in. per 18 ft. of product for expansion and contraction (1/8 in. at each end).
- 30° to 45° scarf joints work well to minimize seams and allow expansion and contraction.
- Glue scarf joints together to help control separation caused by expansion and contraction (see "Bonding, Adhesives and Joinery" section on page 5 for more on proper bonding techniques). Be sure to fasten both sides of the joint.
- Gluing the joints moves the expansion and contraction out to the ends, where movement is covered by Restoration Millwork one-piece corners. However, in some situations glued scarf joints can result in larger gaps at the end of boards when vinyl contracts in cold weather. Expansion joints are an alternative to scarf joints in such situations.
- Expansion joints can also be used to address the effects of expansion and contraction in longer runs where two or more pieces of trim are placed end to end (see page 6 for expansion joint details).
- To cover the gap between boards created by expansion joints, decorative elements like T-bars, keystones and chevrons can be created out of spare pieces of trimboard. See "Ceilings" section on page 6 and "Concealing Expansion Joints" section on page 15 for details.

ProTip™: Use screws to better control expansion/contraction. Screws have heavier shanks than trim nails and are less likely to move.

MOULDING

- Standard wood working machinery is acceptable with speeds of 8,000 RPM or greater.
- Higher RPMs will produce a smoother surface.
- Sharp tooling made of carbide or high speed steel used with hold down clamps and dust collection systems will produce the most desirable finish.

FASTENING

Unless you are using large fasteners or installing TRI-BUILT Exterior Trim in unusually low temperatures (less than 40°F), you will not need to pre-drill holes before fastening.

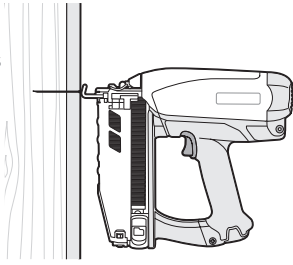

FASTENING SCHEDULE

Use stainless steel or hot-dipped galvanized fasteners designed for wood trim and cladding. For best results, use fasteners with thin shanks, blunt points, and full round heads. We recommend using the CertainTeed Cortex® Concealed Fastening System.

WIDTH OF TRIMBOARD	FASTENERS PER FRAMING MEMBER, 16 IN. O.C.
Less than 6 in.	2
6 in. to 12 in.	3
Greater than 12 in.	4
Sheets	16 in. on center horizontally, 6 in. on center vertically, and 4 in. around the perimeter of the panel

SHEET FASTENING DIAGRAM

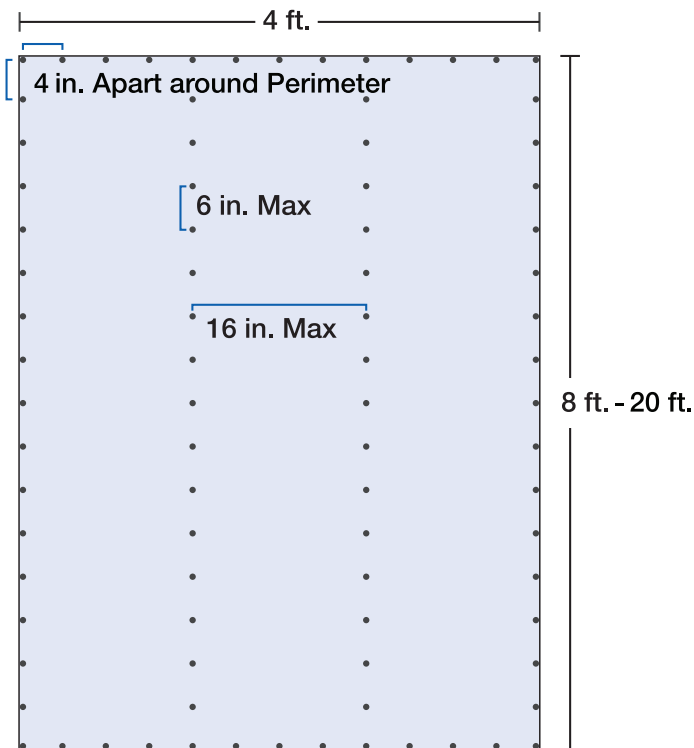

NOTE: Fasteners should be no closer than 3/4" from the edge of the board to avoid blowouts

Do not use brads, staples, wire nails, ring-shank nails, or fine-threaded wood screws.

Choose the correctly sized fastener: 1-1/2 in. of the fastener must penetrate a framing member and/or structural sheathing. If you use 1/2 in. OSB (a type of structural sheathing), the fastener needs to penetrate the framing member only 1 in. If you are covering 1/2 in. foam (non-structural sheathing), you must penetrate the framing member 1-1/2 in. In other words, in the second example, the fastener needs to be longer to meet the fastening requirements.

Note: for sheets - vertical wall fastenings, perimeter fasteners spaced 4 in. apart can be secured into OSB. Fasteners on 16 in. centers must also be secured into framing members.

- Standard pneumatic nailers work well, generally at a pressure between 70 psi and 100 psi, depending upon the type of gun, the type of nail, the air temperature, and the density of the substrate.
- In-line pressure gauges will help maintain even pressure to the nail gun.
- Apply trimboards over framing no greater than 16 in. O.C. If framing members are greater than 16 in. O.C., provide additional bracing for fastening.
- Fastener heads should be flush with the surface of the trim or slightly indented and no closer than 3/4 in. from the end of the board to avoid blowout through the side of the board.
- Fasteners should penetrate a minimum of 1-1/2 in. through a flat, solid wood substrate into a framing member.

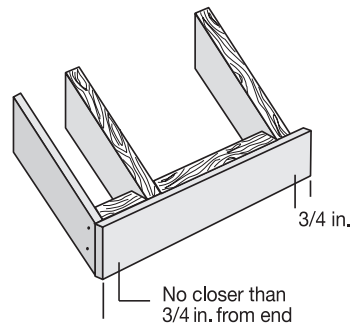
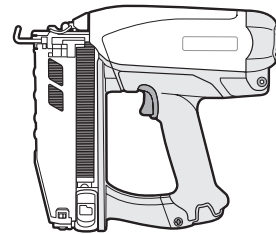

Note: When fastening a pocket accessory, make sure to measure 3/4 in. from the edge of the pocket. Do not fasten through the pocket. For example, to install TRI-BUILT Exterior Trim with a 3/4 in. pocket, measure back 1-1/2 in.: 3/4 in. for the pocket + 3/4 in. for clearance.

Recommended Fastener Sizes for TRI-BUILT Exterior Trim¹

PRODUCT THICKNESS (ACTUAL)	TRI-BUILT EXTERIOR TRIM PRODUCTS AVAILABLE IN THIS THICKNESS	FINISH NAIL MINIMUM LENGTH	#8 TRIM SCREW MINIMUM LENGTH
3/8 in.	Sheets	6D (2 in.)	1-7/8 in.
1/2 in.	Beadboard, Beadboard Panel, Sheets	6D (2 in.)	2 in.
5/8 in.	Trimboards, Sheets	8D (2-1/2 in.)	2-1/8 in.
3/4 in.	Trimboards, Sheets	8D (2-1/2 in.)	2-1/4 in.
1 in.	Trimboards, Sheets, One-piece Corners	8D (2-1/2 in.)	2-1/2 in.
1-1/4 in.	Inside Corner, One-piece Corners, CustomCraft™	10D (3 in.)	2-3/4 in.

¹The recommended lengths and sizes assume that TRI-BUILT Exterior Trim is applied over a nailable, rated structural sheathing (substrate) with a thickness of 1/2 in. applied directly to a framing member. If non-structural sheathing is used over framing members, the fastener must penetrate through the non-structural sheathing into the framing member a minimum of 1-1/2 in.

CORTEX® CONCEALED FASTENING SYSTEM

- The Cortex Concealed Fastening System is designed for use with TRI-BUILT Exterior Trim trimboards with actual thicknesses of 5/8 in. to 5/4 in.
- Using the Cortex setting tool, set the Cortex fasteners perpendicular to the trimboard, spaced a maximum of 16 in. O.C.
- Using a standard 18V cordless impact drill, drive the fastener to the pre-set level below the trim surface.
- Place the PVC trim plug into the hole with the trim-surface-side up, and gently tap until it is flush with the trimboard. To ensure a strong bond, make sure the cored hole is free of dirt or rain water.

GENERAL FASTENING GUIDELINES FOR CORTEX

- For horizontal trimboards more than 12 in. wide, use 4 Cortex fasteners at every framing member, rafter tail, or wall stud.
- If the board is 6 in.–12 in. wide, use 3 Cortex fasteners.
- If the board is less than 6 in. wide, use 2 Cortex fasteners.
- Fasten within 2 in. of the end of each board. If you must fasten within 3/4 in. of the end of the board, use a 3/16 in. drill bit to pre-drill pilot holes.
- For more information on the Cortex Concealed Fastening System and installation with TRI-BUILT Exterior Trim

FASTENING SMALLER, LIGHTER PROFILES

Many of the TRI-BUILT Exterior Trim profiles are narrower and lighter than trimboards, making it difficult to follow the recommended fastening schedule. When applying smaller profile pieces like Base Cap, Quarter Round, Drip Cap, Shingle Mould, Bed Mould, Lattice, or #356 Casing, you can use a shorter and/or thinner gauge fastener, such as a 4d finish nail, to apply the profiles. You may have to pre-drill the profiles, and CertainTeed recommends using adhesives or glues to provide additional holding power.

TOUCHING UP FASTENER HOLES

Fasteners driven beyond the surface of TRI-BUILT Exterior Trim boards can leave unsightly holes in the finished product. To touch up small holes in TRI-BUILT Exterior Trim, we highly recommend using Extreme PVC Trim Welder® Nail Eraser. For best results be sure to follow instructions on package. You can also use caulking or glue products designed for use with cellular PVC millwork to touch up holes, but they may create less than desirable results, weather poorly, or collect dirt over time.

BONDING, ADHESIVES AND JOINERY

GLUING TRI-BUILT EXTERIOR TRIM TO RESTORATION MILLWORK OR OTHER PVC

Use an adhesive designed for use with cellular PVC trim to bond all scarf and miter joints. To bond joints such as corners, window surrounds, and long fascia runs, we recommend Extreme PVC TrimWelder® or Partite 7315 and 7333.

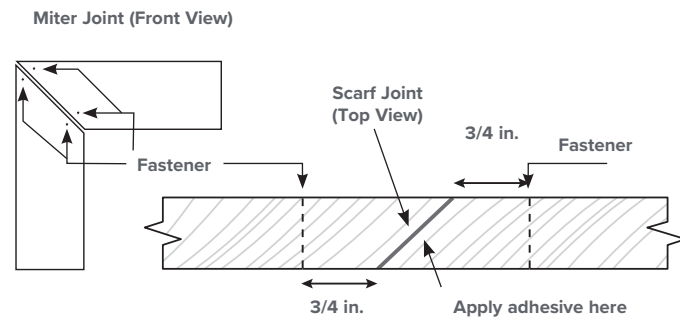

Note: Two Fasteners each side

You can also miter pieces using a Kreg Jig (www.kregtool.com). A Kreg Jig allows you to join two pieces of Restoration Millwork trim by drilling a hole at an angle into one piece of trim and connecting it to another with a self-tapping screw.

- Before you attempt to glue TRI-BUILT Exterior Trim surfaces, make sure the surfaces are clean, dry, and in complete contact. Scarf joints work well when gluing long runs.
- PVC cement and other solvent-based adhesives have different working times, which vary from product to product. To allow sufficient time for a full cure, mechanically fasten the joint on each side staying 3/4 in. away from the edge of the joint.
- To ensure complete curing, make sure the glued pieces are kept clean and adequately ventilated. This is particularly important when bonding large panels face-to-face as inadequate ventilation of solvents can interfere with proper bonding.

ProTip™: Always apply adhesives to TRI-BUILT Exterior Trim following the adhesive manufacturer's recommended application instructions. Press together to get superior bond.

BONDING TO OTHER SURFACES

TRI-BUILT Exterior Trim can also be bonded to a variety of substrates. We recommend OSI® TRIMTeQ™ TeQ Mount™ Mounting Adhesive or Loctite® PL Premium Polyurethane Construction Adhesive. Specific substrate combinations require specific adhesives: contact cement, epoxy, rubber-based adhesives, or urethane-based adhesives.

Use the proper cement for each substrate. Always follow the adhesive manufacturer's instructions, and check the bond on a test piece before proceeding with the installation. Also, be aware of the temperature and humidity, as they can affect the performance of the adhesive.

Note: Never use adhesives alone to fasten Restoration Millwork to a substrate.

RAKES, FASCIAS AND BANDBOARDS

For best results, create a scarf joint by cutting a taper on the end of the trim pieces. Gluing the joints between the trim pieces will help eliminate separation caused by expansion and contraction. Place fasteners on both sides of the scarf joint. This will help minimize expansion and contraction.

- Allow 1/4 in. per 18 ft. of product for expansion and contraction. Allow 1/8 in. at each end of a long run.
- When you apply trim that is less than 6 in. wide, use two fasteners. For trim 6 in. to 12 in. wide, use three fasteners. Trim wider than 12 in. requires four fasteners.
- Fasteners must penetrate the substrate a minimum of 1-1/2 in.

FASCIA WITH RETURN LEG

The TRI-BUILT Exterior Trim Fascia trimboard with built in return leg is designed to work with a wide range of soffit materials. Its one-piece design eliminates installing a J-Channel and gives a cleaner look by hiding end fasteners and cut edges.

When using TRI-BUILT Exterior Trim Fascia with Return Leg, soffit is installed normally.

1. Install soffit material according to manufacturer's requirements.
2. Loosely butt TRI-BUILT Exterior Trim frieze board up to soffit material.
3. Measure and cut height of fascia board to size allowing for enough overhang for the return leg to accommodate the thickness of the soffit material.
4. Install fascia board to subfascia board (minimum 2 X thickness) apply 3 fasteners 16 in. on center across the length of the board. Fasteners should be either 8D finish nails with a minimum 2-1/2 in. length or #8 trim screws with a minimum 2-1/2 in. length. Return leg does not need to be fastened to subfascia board.

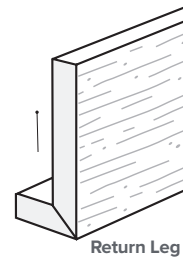

For a clean finished look use Cortex® Hidden Fastening System (includes screws, plugs and setting tools) that conceal fastener heads, offering a fast and simple alternative to face-nailing.

SOFFIT AND PORCH CEILINGS

TRI-BUILT Exterior Trim must not be used in load-bearing applications, but it may be used in spanned applications such as soffit and ceilings.

Before you install TRI-BUILT Exterior Trim as a soffit, review and comply with all local building codes and regulations regarding wall construction, including the proper use of sheathings, framing, weather resistant barriers, flashings, ventilation requirements and other building materials and systems. Irregularities in framing may be visible in the finished application. To minimize the effect of uneven walls, shim the wall as necessary.

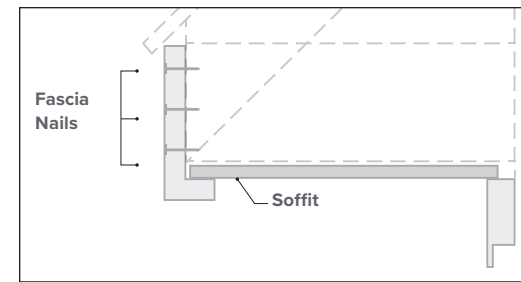

- Proper attic ventilation is important for any home. The 2009 International Building Code (IBC) Section 1203 Ventilation furnishes a basic guide for determining proper ventilation for any home. When using TRI-BUILT Exterior Trim in a soffit or ceiling application the space above must be properly ventilated. Determine the amount of ventilation required for your project and install adequate soffit vents accordingly.

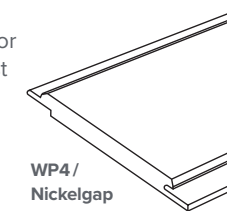

Spanning Schedule for Soffits and Porch Ceilings

Ceiling and soffit applications must not exceed the maximum span without installing blocking or providing additional support by using a minimum 1/2 in. structural sheathing such as plywood or OSB.

PRODUCT	MAXIMUM SPAN (PORCH CEILING/SOFFIT)
BeadBoard Tongue & Groove, 2TL & 3TL	12 in.
BeadBoard Panel	16 in.
Sheets (Minimum 1 in. nominal, 3/4 in. actual thickness)	24 in.
WP4/Nickelgap Tongue & Groove	16 in.

- When applied as soffit, TRI-BUILT Exterior Trim sheets should be applied to structural framing members spaced no more than 24 in. O.C. with the longest dimension perpendicular to the framing.
- If the temperature is 40°F or below at the time of installation, do not span TRI-BUILT Exterior Trim beyond 12 in. In any case, do not span TRI-BUILT Exterior Trim more than 24 in.
- Nail a 2 in. x 2 in. (minimum) nailer board along the wall, with the bottom edge of the nailer board level with the bottom edge of the fascia.
- At every butt joint of the soffit, back up the joint with 2x framing going from the fascia back to the wall. If the soffit corners are going to be mitered, nail 2x blocking from the corner of the fascia to the corner of the wall.
- Apply a high quality construction grade polyurethane adhesive (OSI® TRIMTeQ™ TeQ Mount™ Mounting Adhesive or Loctite® PL

Premium Polyurethane Construction Adhesive) on all joints and/or structural sheathing prior to application of TRI-BUILT Exterior Trim. If you are going to use H-channels at the mitered corners, nail the H-channel to the 2x blocking and slide the cut soffit into it. Cut the soffit 1/8 in. shorter than the H-channel to allow for expansion and contraction.

- Fasten the soffit no closer than 3/4 in. from the side edge, from the butt end, and from the corner. Space the fasteners every 12 in. along both the front and back edge.
- The butt ends should be in contact, fastened at corresponding ends, and supported by framing.

EXPANSION JOINTS FOR SOFFIT AND PORCH CEILING APPLICATIONS

When TRI-BUILT Exterior Trim sheets, Beadboard, Beadboard 2TL or 3TL, or Beadboard panels must be butted together to cover larger soffit or porch ceiling areas, leave space between the pieces to allow for expansion and contraction. The gaps that result from these expansion joints can be covered with a T-bar — fashioned from Trimboards — for a cleaner look that will also hide the small amount of expansion and contraction that may occur. The T-bar is attached to framing with trim nails (no glue) so that the sheets or panels can move freely above it. (See “Concealing Expansion Joints” on page 15 for more details.)

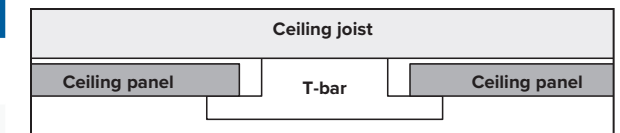

CORNERS

ONE-PIECE OUTSIDE CORNERS

TRI-BUILT Exterior Trim one-piece corners come in both smooth and TrueTexture™ woodgrain finish; in two width options, 4 in. (3-1/2 in. actual) and 6 in. (5-1/2 in. actual); and with or without a built-in J-pocket. All styles are 5/4 in. (1 in. actual) thick, natural white and available in 10 ft. and 20 ft. lengths.

- Flash the corners of the structure by bending a 20 in. piece of trim coil 90° so you have two 10 in. legs. Cover the entire height of the corner, lapping the upper pieces of the flashing over the lower piece.
- Position the corner with the top spaced at least 1/8 in. from the underside of the eave. The distance from the top of the corner to the underside of the eave depends upon the length of the corner. Allow 1/4 in. for expansion for every 18 ft. of corner. Leave the bottom of the corner 3/4 in. below the starter strip if you will be installing vinyl siding, and trim to length.
- Make sure the corner is straight and true before nailing.
- On J-pocket corners and trimboards, the pocket comes back 3/4 in. from the edge of the board. **Do not nail through the J-pocket opening.** Hold the fastener back 3/4 in. from the inside of the J-pocket opening. This means you will be fastening the corner/trimboard 1-1/2 in. from the edge of the board (3/4 in. for pocket + 3/4 in. for holdback = 1-1/2 in.).

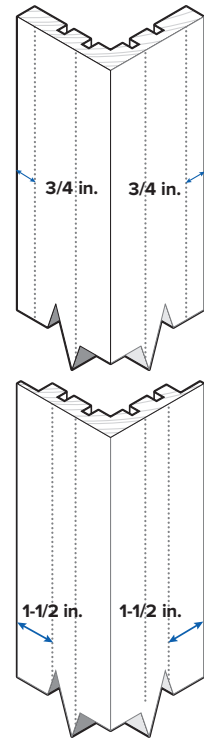

NAIL HEM FLANGE FOR ONE-PIECE CORNER

The grooved design incorporated into TRI-BUILT Exterior Trim one-piece outside corners accommodates traditional face nailing methods. However, for a cleaner installation option, use TRI-BUILT Exterior Trim PVC nail hem flange inserts, which feature molded protrusions that fit directly into the grooves of the corner piece. The flanges provide hidden attachment points for securing the corner piece tightly to the wall. With no nail holes to fill, corners can be finished more quickly and neatly.

Nail hem flanges are 9 ft. 11-3/4 in., so two are needed for each side of a 20 ft. one-piece corner. Space flanges 1/2 in. apart to allow for expansion and contraction. To assemble corner and flanges:

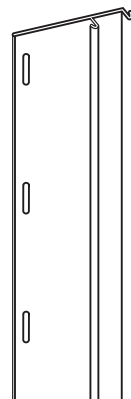

- Use a flat solid surface that supports the corner.
- Insert flange into groove starting from one end.
- To fully seat the flange in the groove, place a piece of scrap Restoration Millwork or wood atop the flange and gently hammer it, working down the length of the flange and ensuring it is fully seated into the grooves. The scrap piece should be taller than the adjacent edge of the corner piece to prevent damaging it.
- Do NOT hammer directly on the flange.
- If the flange slides freely in the grooves, insert a screw through the back side of the flange and into the corner piece near the top, making sure the screw doesn't protrude through the exposed face. One screw per flange should be sufficient.

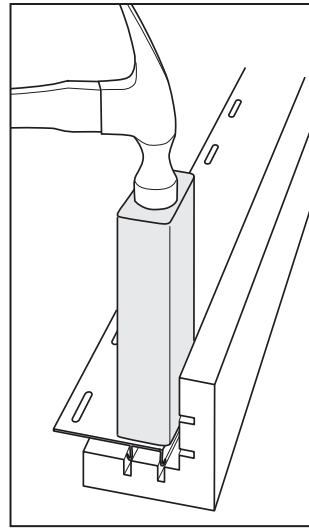

To install one-piece corners with attached nail hem flanges:

- DO NOT NAIL.
- Fasteners must be noncorrosive, self-tapping, pan head or washer head screws, or oval head with countersunk washer screws at least 1-1/8 in. long, with at least 5/16 in. diameter head and 1/8 in. diameter shaft.
- DO NOT SCREW TIGHT. Leave 1/16 in. between the screw head and nail flange to allow for expansion and contraction.
- Position the uppermost screw at the top of the nail slot (Figure A).
- All remaining screws must be positioned in the middle of the nail slots (Figure B).
- Install screws every 12 in. to 16 in.

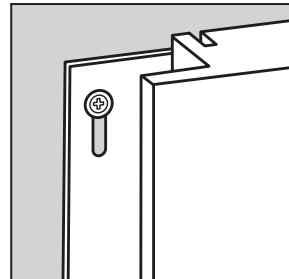

Figure A

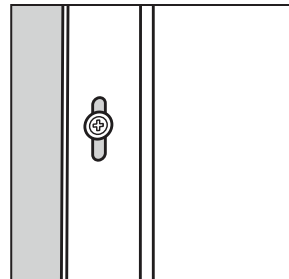

Figure B

ProTip™: If the cornerpost is to be installed on top of a flush surface such as masonry, skirtboard or any other ledge, leave a 1/4 in. - 1/2 in. gap at the top and bottom to allow for expansion.

PACKING OUT TRIMBOARDS TO CREATE A J-POCKET

If you are using a siding product like CedarBoards™ Insulated siding, which requires a 1-1/4 in. pocket height, you may have to pack out TRI-BUILT Exterior Trim trimboards to achieve the desired pocket size. TRI-BUILT recommends using a low-maintenance, durable packing material like TRI-BUILT Exterior Trim to avoid potential future decomposition.

To properly pack out TRI-BUILT Exterior Trim trimboards please follow the instructions below:

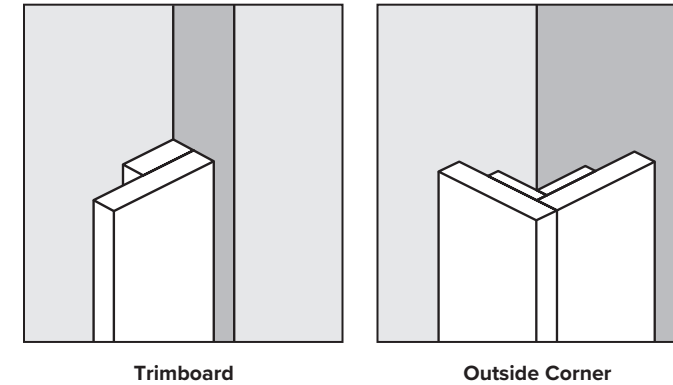

Trimboard

Outside Corner

- Determine the required pocket depth for expansion and contraction (e.g. 12 ft. 6 in. vinyl siding is 1 in.).
- Determine the required pocket height necessary to accommodate the butt edge of the siding being installed (e.g. Monogram® is 3/4 in.). (NOTE: Often times the easiest way to make this determination is to refer to the manufacturer's product guide showing the depths and widths of J-Channel pockets.)
- To determine the thickness of the packing material required behind your trimboard to achieve desired pocket height, use the required pocket height measurement from step 2 above (e.g. if siding choice requires a 1-1/4 in. pocket height the packing material could be made from the TRI-BUILT Exterior Trim CustomCraft™ trimboard). If you plan to use the J-pocket of a pre-routed trimboard or corner, deduct the height of the existing J-pocket from your desired pocket height measurement to determine the required packing material height (e.g. if siding requires a 1-1/4 in. pocket height and you are planning to use a 5/4 in. corner with J-pocket, you would also require a 1/4 in. thick piece of packing material).
- Packing material has a minimum and maximum width based on the size of the covering trimboard being applied over it and the desired pocket depth necessary to accommodate the siding product.
 - MINIMUM PACKING MATERIAL WIDTH:**
The minimum width of the packing material can be no less than 50% of the width of the covering trimboard (e.g. when using a 4 in. trimboard the packing material must be no less than 2 in. wide).
 - MAXIMUM PACKING MATERIAL WIDTH:**
The maximum width of the packing material can be no more than the width of the covering trimboard minus the desired pocket depth (e.g. when using a 4 in. trimboard requiring a 1 in. pocket depth the packing material must be no more than 3 in. wide).

- MINIMUM PACKING MATERIAL WIDTH:**
The minimum width of the packing material can be no less than 50% of the width of the covering trimboard (e.g. when using a 4 in. trimboard the packing material must be no less than 2 in. wide).
 - MAXIMUM PACKING MATERIAL WIDTH:**
The maximum width of the packing material can be no more than the width of the covering trimboard minus the desired pocket depth (e.g. when using a 4 in. trimboard requiring a 1 in. pocket depth the packing material must be no more than 3 in. wide).
- Apply packing material, then install covering trimboards over packing material. Use appropriate length fasteners for both packing material and covering trimboards that allows the fastener to penetrate through the substrate and into a framing member a minimum of 1-1/2 in.

TWO-PIECE OUTSIDE CORNERS

To fabricate your own corner, miter or butt the trimboards together and seal the joint with a PVC adhesive like Extreme PVC TrimWelder® or Partite 7315 and 7333. PVC adhesives have a very short open time, so when gluing PVC trim, do not apply the adhesive until you are ready to bring the two pieces together.

- For butted joints, apply adhesive to the end of the trim, and fasten the corner pieces together. Use a fastener through the butt every 16 in. Let the corner cure, and install as described for one-piece corners.
- For mitered corners, assemble the corner before installing it. Cut the miter angles, apply adhesive to the length of the miter, and fasten the corner pieces together.
- Let the corner cure and install as described for one-piece corners.

ProTip™: If building a butted corner, the piece that butts against should be installed on the less visible wall to hide the joint line.

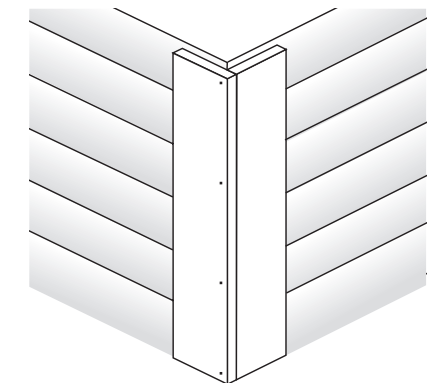

Butted

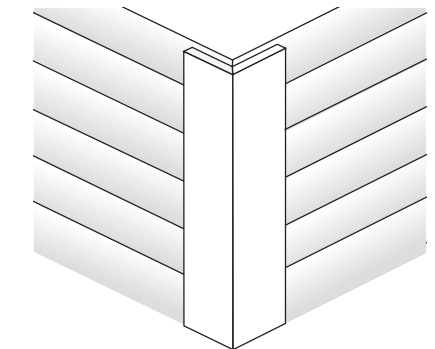

Mitered

SKIRTBOARD

TRI-BUILT Exterior Trim skirtboard is used as a starting course for fiber cement siding; when transitioning from lap siding to shingle siding; and at transition points such as horizontal wall-to-roof intersections (frieze board), masonry-to-siding intersections, and where fiber cement siding meets decks and patios. TRI-BUILT Exterior Trim skirtboard's DualStart® reversible feature provides design flexibility — TRI-BUILT's exclusive TrueTexture™ woodgrain finish on one side, a smooth finish on the other, with top and bottom edges identically beveled.

CUTTING

Cut TRI-BUILT Exterior Trim skirtboard with a conventional carbide-tipped wood-working blade. Do not use fine-tooth metal-cutting blades.

EXPANSION AND CONTRACTION

- Allow 1/4 in. per 18 ft. of product for expansion and contraction (1/8 in. at each end).
- Use 30° to 45° scarf joints to minimize seams and allow expansion and contraction.
- Glue scarf joints between the pieces to help control separation caused by expansion and contraction. Gluing the joints moves the expansion and contraction out to the ends.
- Be sure to fasten both sides of the joint.

FASTENING

- Use stainless steel or hot-dipped galvanized fasteners designed for wood trim and cladding. For best results, use fasteners with thin shanks, blunt points, and full round heads.
- Standard pneumatic nailers work well, generally at a pressure between 70 psi and 100 psi, depending upon the type of gun, the type of nail, the air temperature, and the density of the substrate.

NOTE: Do not use brads, staples, wire nails, ring-shank nails, or fine threaded wood screws.

Skirtboard must be applied over a rigid sheathing that provides a smooth, flat surface or an underlayment that is no more than 1 in. thick. Do not apply skirtboard directly to studs.

Do not install skirtboard over questionable wall construction. Irregularities in framing may become visible in the finished application. To minimize the effect of uneven walls, shim the wall as necessary.

INSTALLING SKIRTBOARD WITH FIBER CEMENT LAP SIDING

Before installing fiber cement lap siding, fasten the skirtboard the same way you would install a trimboard:

- Make sure the skirtboard is level.
 - Fasteners must penetrate a minimum of 1-1/2 in. through a flat, solid wood substrate into a framing member.
 - Apply skirtboard over framing no greater than 16 in. on center. If framing members are greater than 16 in. on center, provide additional bracing for fastening.
 - Fastener heads should be flush with the surface of the skirtboard or slightly indented and no closer than 3/4 in. from the end or edge of the board.
- Use two fasteners per framing member for 6 in. skirtboard and three fasteners per framing member for 8 in. skirtboard.
- Metal flashing must be installed above the skirtboard before installation of lap siding begins. Flashing should be positioned so that it overlaps the beveled angle at the top of the skirtboard to allow water to flow out and over the board.
- Position the first course of lap siding so that the bottom edge hangs a minimum of 1/4 in. over the top of the skirtboard.

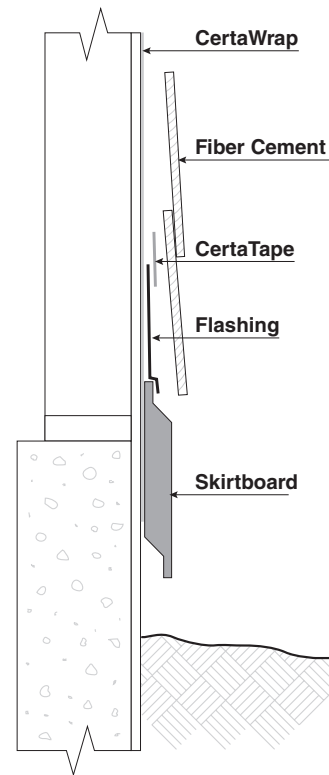

TRANSITIONING FROM LAP SIDING TO SHAKES SIDING

- Metal flashing must be installed above the skirtboard before installation of lap siding begins. Flashing should be positioned so that it overlaps the beveled angle at the top of the skirtboard to allow water to flow out and over the board.
- Install the skirtboard so that it extends a minimum 1/4 in. over the top of the lap siding.
- Install a siding starter course.
- Align the bottom edges of the Shakes siding and the starter course. Position the first course of Shakes siding so that the bottom edge hangs a minimum of 1/4 in. over the top of the skirtboard.
- Use CertaTape™ Construction tape or similar product to seal penetrations where flashing is nailed to substrate.

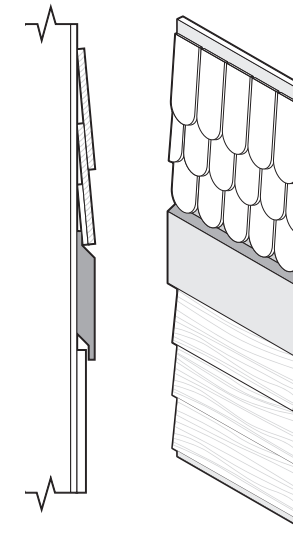

CONVERTING SKIRTBOARD TO FRIEZE BOARD

TRI-BUILT Exterior Trim skirtboard can be easily converted for use as frieze board.

- Simply cut the beveled angle at the top of the skirtboard to create a square edge.
- Remember: Skirtboard can be reversed to display either a woodgrain or smooth finish, so be sure the desired finish is facing outward before cutting the board.

WINDOW AND DOOR TRIM

CREATING A POCKET TO ACCOMMODATE A NAILING FLANGE

TRI-BUILT Exterior Trim J-pocket trimboards with nailing flange are factory routed to ensure a consistent fit and to speed installation of the trimboards around windows with nailing flanges. However, occasionally you will need to create a pocket to accommodate a nailing flange in the field.

1. Measure the width of the nailing flange of the window at the opening where you plan to apply trim.
2. Set the blade depth of your table saw approximately 1/8 in. higher than the width of the window nailing flange.
3. Set the table saw fence so you are cutting away only the thickness of the saw blade from the trimboard.
4. Make one cut from the back side of the trimboard on your table saw.
5. Check to be sure the trimboard will lay flat against the wall and that all joints are tight prior to fastening. If the boards do not lay flat against the wall or the joints are not tight, repeat the above instructions starting at step 3.

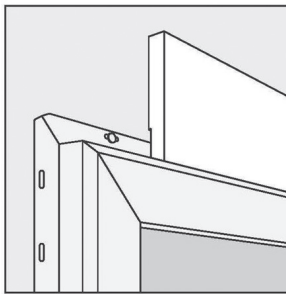
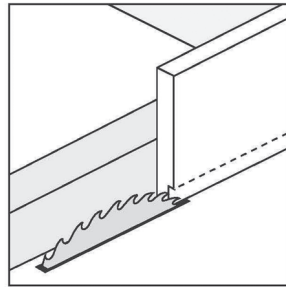

THE INVISIPRO® HIDDEN FASTENING SYSTEM

To help you finish window, door and other openings more quickly and neatly, the InvisiPro System, providing hidden attachment points for trim pieces and eliminating the need to fill nail holes.

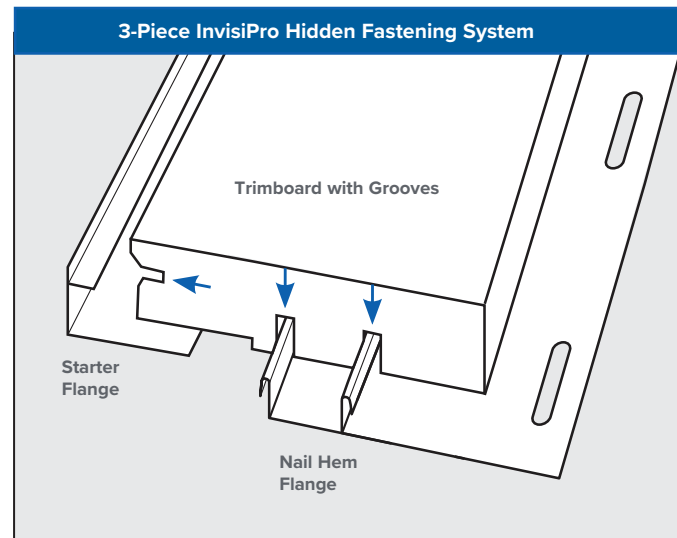

- Start by cutting pieces to match the width (top and bottom) and height (sides) of the opening. Cut a starter flange and nail hem flange to the exact length of each side of the opening.
- Install the starter flange around the edge of the window, fastening every 8-10 in.

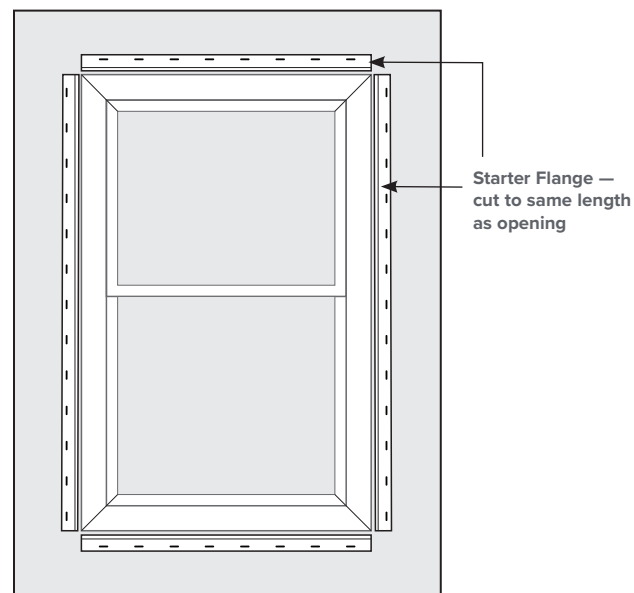

- Cut trimboards so that bottom dimensions are the same as those of the starter strips and flanges, but the top dimensions are longer to create 45° angles at each end of the trimboards. These angles will be fitted together to create attractive mitered trim corners.

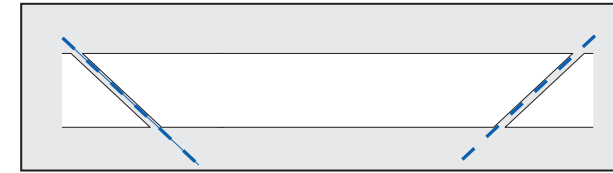

To assemble the trimboards and flanges:

- Use a clean, flat and solid surface that supports the trimboard.
- Insert the nail hem flange into the groove, starting at one end. To fully seat the flange, place a piece of scrap TRI-BUILT Exterior Trim or wood atop the flange and gently hammer it, working down the length of the flange and ensuring it is fully seated into the grooves.

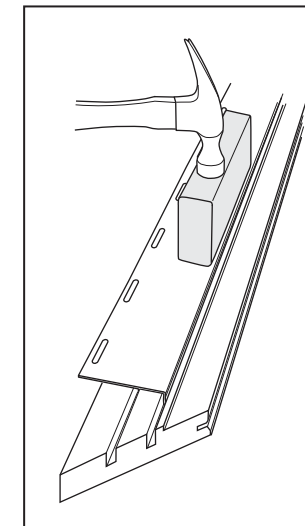
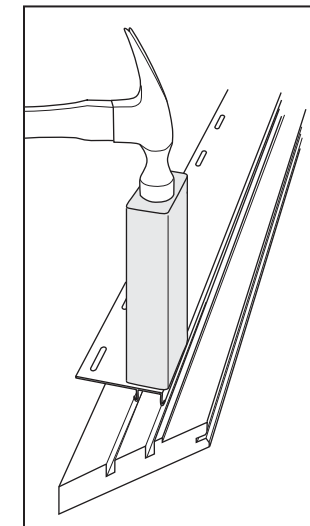

Do NOT hammer directly on the flange.

- Drill a pilot hole perpendicular to the angle at both ends of the top and bottom trimboards approximate 3/4 in. from the edge.

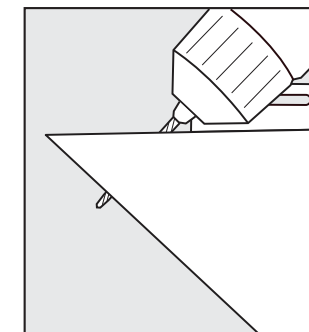

ProTip™: Flashing Windows and Other Openings

- Cladding and trim are not meant to be watertight barriers. Before you install any cladding materials or trim, flash all openings so that they shed water to the exterior of the cladding and trim materials.

Now you're ready to install the trimboard/flange assembly.

- Starting at the top of the opening, insert the top trimboard into the starter strip.
- Attach the nail hem flange to the wall using roofing nails.
- Apply PVC adhesive to the edge of the angled miters of the top trimboard.
- Insert a side trimboard into the starter strip, align the two mitered corners, and attach the nail hem flange to the wall using roofing nails. Repeat procedure at other side.
- Insert screws into the pre-drilled pilot holes in the top trimboard and drive them in to reinforce the adhesive bond.
- The bottom trimboard is the last piece to be installed, following the same steps you used for the top trimboard.

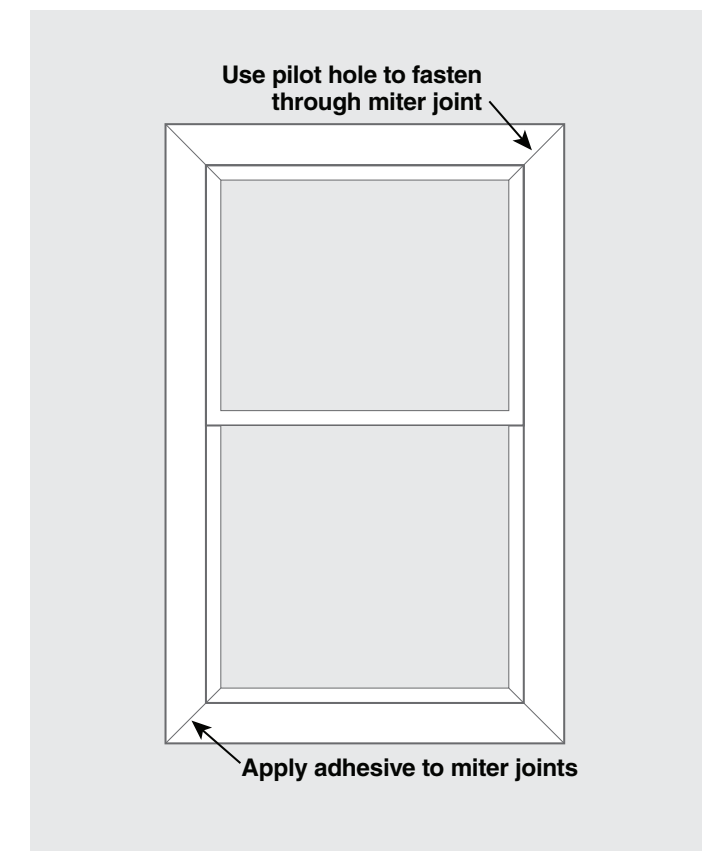

COLUMN WRAPS

TRI-BUILT Exterior Trim Column Wrap comes in a standard 9 ft. length and in finished sizes of 8 in. x 8 in. and 10 in. x 10 in.

SPACER BLOCKS

The spacer blocks that are supplied are designed to accommodate installing the wrap around a 4 in. x 4 in. wood column. If you are installing over a 6 in. x 6 in. wood column, trim the width of the spacer blocks using a table saw.

Wood Column Size	Wrap options	Spacer Block Size*	Trimming Required
4 in. x 4 in.	8 in. x 8 in.	6-7/8 in. x 1-9/16 in.	No
4 in. x 4 in.	10 in. x 10 in.	8-7/8 in. x 2-9/16 in.	No
6 in. x 6 in.	8 in. x 8 in.	6-7/8 in. x 5/8 in.	Yes (Width)
6 in. x 6 in.	10 in. x 10 in.	8-7/8 in. x 1-9/16 in.	Yes (Width)

**Note: Sizes can vary due to differences in the size of the wood post.*

- Install the spacer blocks to the wood post. If you are installing railing, you will also need to install blocking at the rail attachment points.
- Measure up 11 in. from the floor; mark the centers of the post and the spacer blocks.
- Install two spacer blocks on opposite sides of the post.
- Install the remaining spacer blocks over the ends of first two blocks.
- Repeat this procedure at the top of the post, 11 in. down from ceiling.

Note: If you intend to attach railing to the column you must install additional spacer blocks to the wood post at the position where your railing brackets are to be mounted.

COLUMN WRAP

- Measure height of installation area (from floor to header or ceiling) for total installation height. NOTE: If installing Estate column wrap, you must first install the top trim blocks before measuring for height.
- Cut column wrap to length, 1/2 in. shorter than total installation height. If using for 10 foot install do not cut column.
- Open column by peeling back the four pieces of tape half way. Do not fully remove tape as it will be used to hold the corner together for gluing.
- Wrap column around post. Attach column to blocking with two nails or screws (1-1/2 in.) on three sides. Fourth side will be attached after corners are glued.

Note: When using for 10 foot column install with bottom of column even with lower blocking. Supports must be used to hold the column at height. Supports are used to carry the weight of the column to the floor. Be sure to leave 1/2 in. gap between top of column and ceiling. You need to add blocks for the base trim with this installation. (Not provided)

GLUE

- Apply bonding adhesive to unglued corners. A 1/8 in. bead along the total length is recommended. Refer to page 5 for the recommended adhesives.
- Close open side and reattach the four pieces of tape. Once adhesive has set the tape can be removed. Attach fourth side to blocking with two nails or screws. (1-1/2 in.)

TRIM

- Classic Column Trim:
 - Apply bonding adhesive to two corners and fold to create “U”. A 1/8 in. bead along the total length is recommended.
 - Wrap trim around column wrap. Attach trim to column with two nails or screws (1-1/2 in.) on three sides.
 - Apply bonding adhesive to unglued corners. A 1/8 in. bead along the total length is recommended.
 - Close open side and hold closed with piece of tape. Attach fourth side to column with two nails or screws (1-1/2 in.).
 - Attach Base Cap profile to trim box with adhesive and two nails per side.
- Estate Column Trim
 - Follow instructions for Classic column trim for base trim.
 - Attach Rack profile to base of trim with adhesive and two nails per side.
 - Estate column mid trim: Measure down 10 inches from the top of the column. Attach Base Cap profile with two nails per side. Be sure profile is level. Repeat for other three sides to form mid trim.
 - Estate column top trim: Attach Rack profile with adhesive and two nails per side to the top of the column wrap.

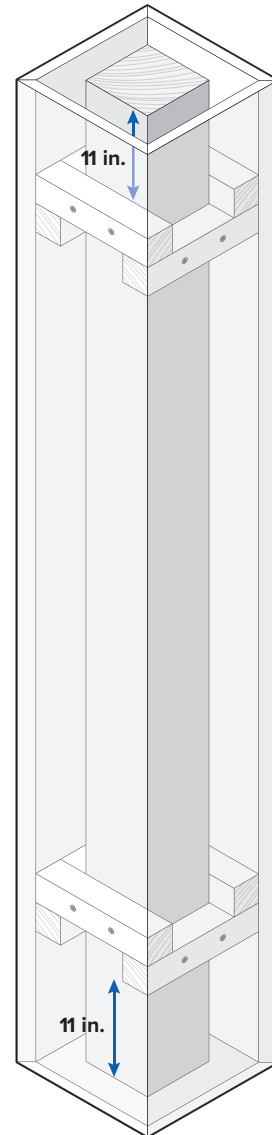

FINISH

Countersink all fasteners and fill with Extreme PVC TrimWelder®. If painting, clean and prep surface for finishing. Painting is not required. Apply two coats high quality exterior 100% acrylic latex paint. Follow paint manufacturer’s instructions. For colors with a light reflective value of 55 or lower use Vinyl Safe Paint.

BEADBOARD

EXPANSION AND CONTRACTION

When installing TRI-BUILT Exterior Trim Beadboard, allow 1/8 in. for expansion and contraction at all edges and around fixed objects or abutments.

FASTENING BEADBOARD PANELS

- Apply construction adhesive such as OSI® TRIMTeQ™ TeQ Mount™ Mounting Adhesive or Loctite® PL Premium Polyurethane Construction Adhesive to the back of the panel where it will intersect joists or contact substrate.

- Fasten TRI-BUILT Exterior Trim Beadboard panels to framing members, spacing fasteners no more than 6 in. apart in the field and 4 in. apart at the perimeter of the panel (see Fastening Diagram on page 3).

FASTENING BEADBOARD 2TL AND 3TL

- Apply construction adhesive such as OSI® TRIMTeQ™ TeQ Mount™ Mounting Adhesive or Loctite® PL Premium Polyurethane Construction Adhesive to the back of the beadboard where it will intersect joists or contact substrate.
- TRI-BUILT Exterior Trim Beadboard 2TL and 3TL should be nailed a maximum of 12 in. O.C. along its length with fasteners at least 2 in. but no closer than 3/4 in. from the end of each board.
 - For spans greater than 12 in. O.C., use a minimum 1/2 in. backer such as plywood or OSB with construction grade adhesive and mechanical fastening a minimum of every 8 in. Fasteners should hit joists or framing members whenever possible.

Spanning Schedule for Soffits and Porch Ceilings

Product	Maximum Span (Porch Ceiling/Soffit)
BeadBoard Tongue & Groove, 2TL & 3TL	12 in.
BeadBoard Panel	16 in.
Sheets (Minimum 1 in. nominal, 3/4 in. actual thickness)	24 in.
WP4/Nickelgap Tongue & Groove	16 in.

- TRI-BUILT Exterior Trim Beadboard 2TL and 3TL also feature a flange for easier blind-fastening. Use this flange to fasten beadboard for runs up to 18 ft. For runs longer than 18 ft., additional face fastening and/or application of construction adhesive at the substrate or along framing members will help restrict expansion and contraction.

WAINSCOTING APPLICATION

- When installed as wainscoting, TRI-BUILT Exterior Trim Beadboard Panels and Beadboard 2TL and 3TL must be applied over a solid substrate. Verify that substrate is level prior to application.

CONCEALING EXPANSION JOINTS

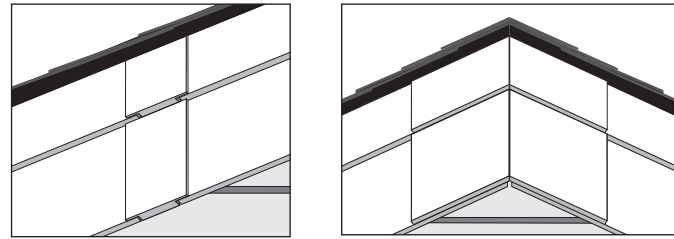

Keystone

Chevron

Decorative elements that conceal the gaps created by expansion joints can be fashioned from spare pieces of Restoration Millwork Trimboard. keystones work well for long, straight runs. Chevrons are the right shape for angled areas like roof peaks, while T-bars are a good choice for flat, horizontal areas such as soffit and porch ceilings.

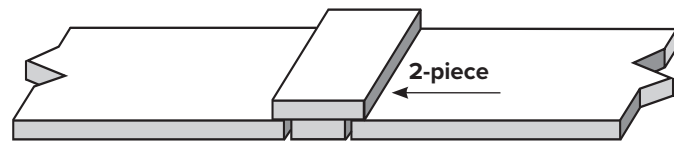

2-piece

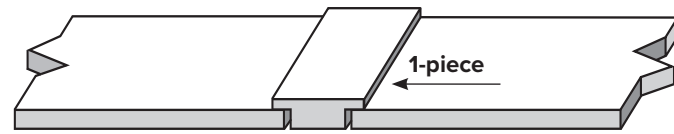

1-piece

T-bar

- The size of the gap at an expansion joint depends upon the temperature at the time of installation.

Temperature	Recommended Gap Size
100+ degrees	No Gap, tight all sides
50-100 degrees	1/8 in. Gap at joint, 1/16 in. Gap at edges
Below 50 degrees	1/8 - 1/4 in. Gap at joint, 1/16 in. Gap at edges

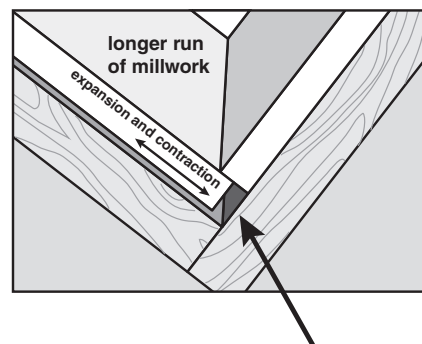

Hidden expansion joints in long runs

This is achieved by controlling one end and letting the other end be the outlet for expansion and contraction.

PAINTING

TRI-BUILT Exterior Trim comes in natural white and does not require painting for protection. If you want to paint it a custom color, follow these important guidelines:



- As with any surface to be painted, the trim must be clean and dry and free of chalk, grease, oil, dirt, or mold and mildew. To ensure good adhesion to the surface, scuff sand TRI-BUILT Exterior Trim before you paint.
- To scuff sand TRI-BUILT Exterior Trim trim, use 100–120 grit sandpaper or a Norton Abrasive Sponge.
- Verify that the coating manufacturer requires or approves of applying primer prior to paint application. Applying primer may reduce the drying time of the topcoat.
- For the highest quality finished appearance, use an airless sprayer to apply paint to all TRI-BUILT Exterior Trim products. You can also use either a roller or brush, but a roller produces a more consistent appearance. Surfaces may be rolled then brushed to speed application, but avoid leaving some areas brushed with other areas rolled as it will affect the finished quality.
- Ambient temperature, humidity, and other location-related factors can affect the drying times of coatings applied to PVC millwork. Discuss these factors with your paint distributor when choosing coating products. Good planning for jobsite conditions will lead to great results.
- Apply a 100% acrylic latex paint with an LRV (light reflective value) of 55 or higher. Generally, the higher the LRV, the lighter the color.
- Sherwin-Williams® VinylSafe™ Technology or AquaSurTech coating colors should be used when choosing darker colors that have a Light Reflecting Value (LRV) of 54 or lower. For colors with an LRV of 55 or higher (the higher the LRV, the lighter the color), you can safely use an acrylic latex paint.
- Always follow the paint manufacturer's recommendations for the use and application of the paint.
- Due to the extended cure times of paint applied to PVC cellular trim, we recommend installing TRI-BUILT Exterior Trim first and then painting it, unless the trim is painted in a professional prefinishing operation and allowed to cure completely.

TRI-BUILT is not liable for paint used on TRI-BUILT Exterior Trim and/or the results of its use.

BENDING

Take care when handling heated materials, as hot PVC can produce severe burns. Wear protective gloves that are thick enough to avoid burns.

Convection air circulating ovens, strip heaters, and radiant heaters can be used to successfully bend TRI-BUILT Exterior Trim exterior trim. These proven methods will produce a minimum amount of deformation in the shape and finish of the trim.

However, the ability to bend TRI-BUILT Exterior Trim trim is limited—not all pieces can be successfully bent. For best results, do not bend any PVC cellular trim that is more than 6 in. wide.

Heat guns can also be used to bend small areas where appearance and uniformity are not critical. However, some experimentation may be necessary to perfect this "art." Take care not to overheat the material, as overheating can produce a rough texture and discoloration. When you bend textured cellular PVC, the wood grain will distort or disappear, depending upon the radius of the bend. Refer to "Finishing" on page 2.

Sheet goods can often be used in a cost-effective manner to create the shapes needed for trimming out geometric areas of design on a project, eliminating the need to heat-bend trimboards.

To bend TRI-BUILT Exterior Trim:

- To guarantee uniformity, gradually increase the temperature, and heat both sides of the material simultaneously. Temperatures should be controlled to prevent the surface temperature of the product from exceeding 300 degrees Fahrenheit for more than ten (10) minutes.
- In general, heating time is about 3 minutes for each 1/4 in. of thickness of material. When the trim's shape is irregular or the heat is not uniform, heating times may be longer.
- Apply the heat evenly until the trim becomes flexible and easy to form.
- A forming jig is recommended to achieve and maintain the desired shape and dimensions.

CLEANING

Use a soft bristle brush and a bucket of soapy water to remove normal dirt and grime. For especially stubborn stains or for mold or mildew, use a cleaner suitable for PVC products. Your local building materials retailer can supply several different brands, but test any cleaner on an inconspicuous area before you use it.

ProTip™: Small dents in TRI-BUILT Exterior Trim can sometimes be removed using a hair dryer or heat gun. We recommend practicing on a test piece first.

GLOSSARY

Because this manual was written for building professionals, we have freely used the language and jargon of the siding industry. To avoid confusion, we thought it a good idea to share our understanding of each of these terms with you.

Actual Dimensions—The exact measurement of a piece of trim or trimboard.

Band Board—A decorative piece of horizontal trim placed between two floors along the rim joist.

Beadboard—A flat panel or sheet routed with a beaded detail at regular intervals. Typically used for wainscoting and porch ceiling applications.

Beaded—A narrow, half-round molding at the base of a lap siding panel.

Casing—Molding of various widths used to trim door and window openings at the jambs; also referred to as lineal, window, or door surround.

CCMC—Canadian Construction Materials Centre.

Contraction—Commonly refers to building products contracting due to a decrease in outside temperature.

Cornice—The overhang of a pitched roof at the eave line, usually consisting of a fascia board, a soffit for a closed cornice, and appropriate moldings.

Countersink—To secure a fastener to sit flush with or below the surface of the surrounding material.

Course—A row of siding panels running the width of the wall.

Dormer—A gabled extension built out from a sloping roof to accommodate a vertical window.

Drip Cap—A horizontal flashing placed over exterior door or window frames to divert rainwater.

Eave—The overhang of a pitched roof at the bottom edge, usually consisting of a fascia board, a soffit for a closed cornice, and appropriate moldings.

Embossing—Woodgrain pattern rolled or formed into the face of an extruded vinyl building material to create a wood-like appearance.

Expansion—Commonly refers to building products expanding as outside temperatures increase.

Expansion and Contraction—Commonly refers to construction material expanding when heated up or contracting when cooled, especially as outside temperature changes.

Expansion Joint—An expansion joint is an assembly designed to safely absorb the heat-induced expansion and contraction of various construction materials.

Face—The side of the siding, trim, or soffit that is exposed to view after the product has been installed.

Fascia—A flat, horizontal band that covers the rafter tails and runs along the bottom edge of the roof line.

Fastener—Generic term for nails, screws, bolts, and metal hardware.

Flashing—A thin, impervious material, usually metal, placed around openings to prevent water penetration or to direct the flow of water over the cladding.

Frieze—The horizontal trimboard connecting the top of the siding with the soffit.

Furring/Furring Strip—Long, thin strips of wood or other materials used to build out the fastening surface of a wall; commonly used to correct imperfections in wall surfaces, to establish a rainscreen, or to re-establish a structural fastening surface on the exterior of nonstructural products such as foam insulation.

Gable—The triangle formed on the side or the front of a building by a sloping roof.

Hot-dip Galvanized—The process of dipping metal into molten zinc to apply a protective coating that prevents corrosion; hot-dipped galvanized iron and steel are corrosion resistant.

IBC—International Building Code

ICC—International Council Code

Keyway—A recess or groove in a manufactured shake or shingle siding panel.

Kick-Out Diverter Flashing—A flashing piece located where sloped roofs meet vertical walls; designed to divert water into a gutter.

Lap—Where two siding panels join horizontally, one over the other.

Light Reflecting Value (LRV)—A measure of the amount of light that is reflected off a surface. Generally, the higher the LRV, the lighter the color.

Lineal—Molding of various widths used to trim door and window openings at the jambs; also referred to as casing, window, or door surround.

Mechanically Fasten—The joining of two or more materials through the use of fasteners such as nails, bolts, or screws.

Miter Cut—A beveled cut, usually 45°, made at the end of a piece of molding or board that is used to form a mitered joint.

Nickel Gap—Refers to the fine line pattern of shiplap, but with a perfect 1/4" gap in between each board.

Nominal Dimensions—The identifying dimensions of a piece of lumber; for example, a 2 x 4 is the name for a rough-cut piece of about 2 in. x 4 in.; nominal dimensions are usually larger than actual dimensions.

Pneumatic Nailer—A nail gun or nailer is a type of tool used to drive nails into wood or other material. It is usually driven by compressed air.

On Center (O.C.)—A measurement of the distance between the centers of two repeating members in a structure, usually studs.

OSB—Oriented Strand Board.

Packing Out—The process of installing substrate under a finish piece to achieve the proper lift or gap upon installation of a piece of trim.

Pre-drill—Before using a fastener to secure material like TRI-BUILT Exterior Trim, drill a hole first to avoid cracking the material with the fastener.

Profile—The contour or outline of a trim piece as viewed from the side.

PVC—Polyvinyl chloride, the plastic resin used to manufacture vinyl building products.

PVC Trim—Trim stock made of polyvinyl chloride

Rainscreen Wall—A method of constructing walls in which the cladding is separated from a membrane by an airspace that allows pressure equalization to prevent rain from being forced in. It consists of an exterior cladding, a cavity that is typically created through the use of furring strips behind the cladding, and an inner wall that incorporates a weather-resistant barrier.

Rake—Trim members of a gable roof that run parallel to the roof slope from the eave to the ridge.

Recommended Span—The distance a building material can safely traverse without being supported underneath.

Rigid Sheathing—Plywood, OSB, or foam sheathing.

Rim Joist—The board that the rest of the joists are nailed to. It runs the entire perimeter of the house.

Rip Cut—A cut made lengthwise on a piece of siding or trim.

Scarf Joint—A scarf joint (also known as a scarph joint) is a method of joining two members end to end. The scarf joint is used when the material being joined is not available in the length required.

Sheathing—Sheets of plywood, exterior gypsum board, or other material nailed to the outside face of studs as a base for exterior siding.

Shim—A building material, usually wood, used to even a surface.

Skirtboard—Treated lumber or PVC trimboard installed horizontally; used as a transition from foundation to siding or as a starter strip.

Soffit—The underside of an overhanging eave.

Square—Unit of measure for siding; equal to 100 square feet of exposure (e.g. a 10-ft. by 10-ft. wall section = 100 square feet = 1 Square).

Span—The distance between supports.

Starter Strip—An accessory used to engage the locking leg of the first course of siding.

Structural Member—A support that is a constituent part of any structure or building.

Structural Sheathing—The layer of boards, wood or fiber materials applied to the outer studs, joists, and rafters of a building to strengthen the structure and serve as a base for an exterior cladding.

Substrate—A layer of material applied over the studs at the exterior walls of a building.

Weathering—Photochemical degradation of the surface of a material caused by the combination of sunlight (UV radiation), water, and abrasion by wind-blown sand, dirt, or other particulates. In wood and other building materials, weathering is characterized by color change. Excessive weathering of unfinished wood can cause checking, cracking, and splintering.

Weather-Resistant Barrier—A building membrane that protects building materials from exterior wind and water penetration.

WP4—A flat panel or sheet with a tongue and groove joint that forms a 1/2" wide, v-shaped channel.

NOTE: When the terms “recommend” and “should” are used in this manual, the step is optional for installing TRI-BUILT Exterior Trim. However, it is included because the step represents best practice. When the terms “required” and “must” are used, the step is a necessary part of the installation process and must be adhered to.

TRI-BUILT® EXTERIOR TRIM PRODUCT LINE

TRADITIONAL PROFILES: All trimboards and outside corners are available in smooth and woodgrain.

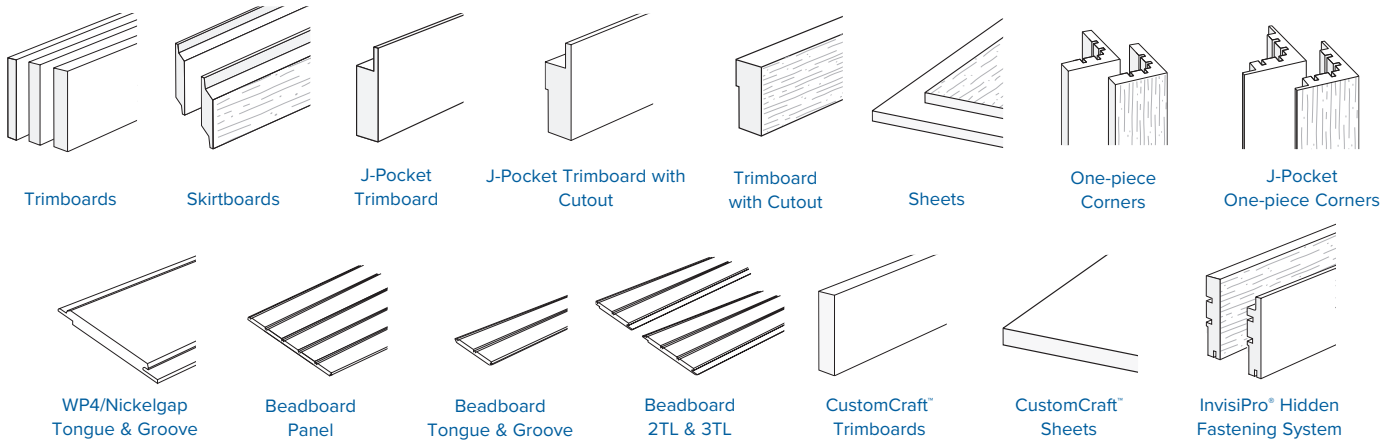

SPECIALTY PROFILES

